

# HOW TO MAKE A PRINT IN THE DARKROOM

1. With the china marker, select (circle) your **BEST 5** images. Please review these selections with me.



2. Remove negative from sleeve and clean with anti-static cloth. (orange cloth in your drawer)

3. Lift lever for negative carrier, and remove negative carrier from enlarger.

## ENLARGER PARTS

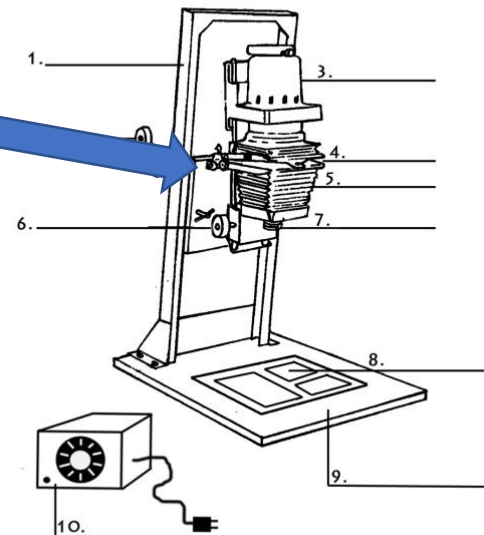
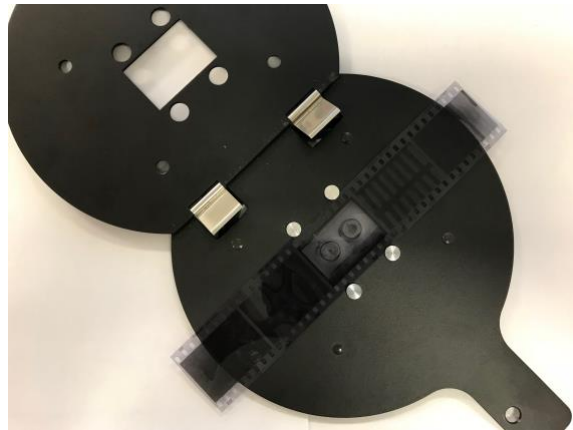

4. Slide negative, emulsion (shiny) side up, under the four pins in your negative carrier.

5. Close carrier and adjust your negative. Make sure you don't see any of the clear areas around your image.

Copyright © Jill Dulgeroff - Madeira High School - 2016



6. Insert negative carrier into enlarger, while holding the handle and close lever for the negative carrier.
7. If you see any white areas around your image, you need to adjust your negative. Grab one end of your negative and wiggle it slowly.

8. Unlock your enlarger and adjust the height of your enlarger to fill the 5x7 opening on your easel. Remember to focus every time you move the height of your enlarger.



9. Open your aperture to  $f/3.5$  and focus. Use the grain focuser to fine tune your focus.



10. Select the appropriate aperture for exposure. You need to even out the darks and lights in your image.
11. If a filter is needed, insert filter into carrier.
12. Create a test strip. 2 second intervals.
13. Once you have determined the exposure time, place 5x7 paper in the easel. Make sure to slide paper up to the tabs.
14. Expose your paper at the determined time.